

SOLAR PUMP

PROFESSIONAL SOLAR PUMP MANUFACTURER

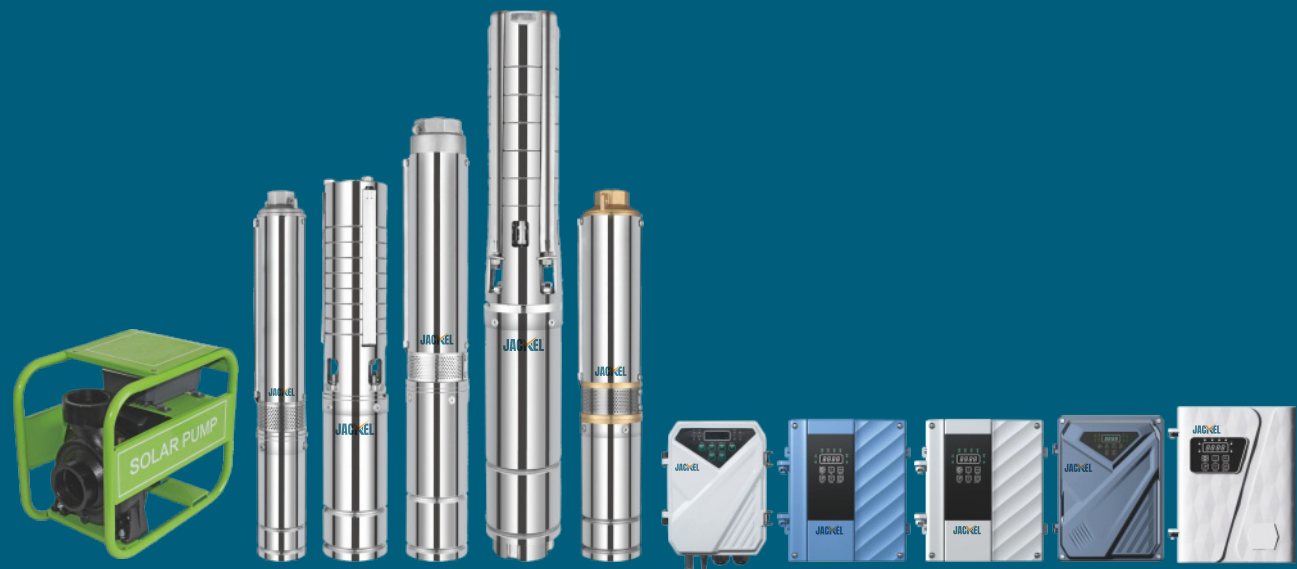

CONTROLLER

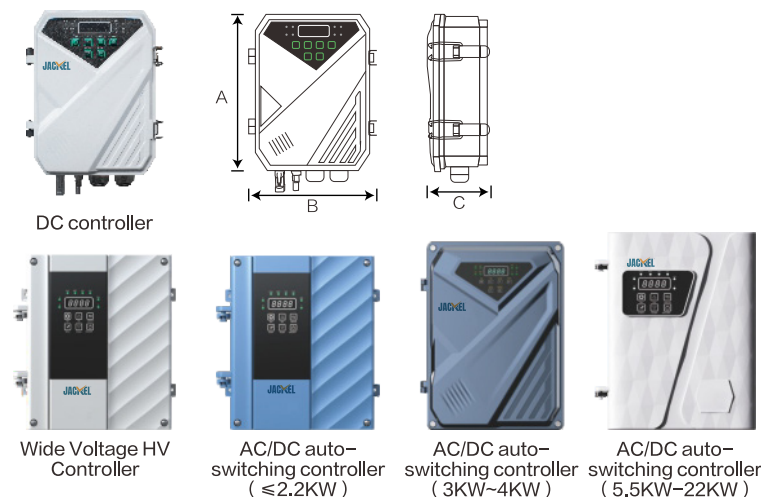

TECHNICAL DATA

Model	Dimensions (cm)			Weight(kg)
	A	B	C	
DC controller	21.5	18	8	1.5
Wide voltage HV controller	24	23	11	2.2
AC/DC auto-switching controller (≤2.2KW)	24	23	11	2.3
AC/DC auto-switching controller (3KW-4KW)	29	23	11	2.5
AC/DC auto-switching controller (5.5KW-22KW)	30.5	25.5	16	5.5

WORKING ENVIRONMENT AND ELECTRICAL PROPERTY

Controller and Pump Matching Method					
Controller Model	Adaptable Pump	Max.Input Current (A)	Max.Open Circuit Voltage (V)	Optimum MPPT Voltage(v)	Working Temperature (°C)
DF-12	Rated 12V Pump	17	<55	30-48	-15 ~ 60
DF-24	Rated 24V Pump	17	<55	30-48	-15 ~ 60
DF-36	Rated 36V Pump	17	<55	30-48	-15 ~ 60
DF-48	Rated 48V Pump	17	<105	60-90	-15 ~ 60
DF-72	Rated 72V Pump	17	<160	90-120	-15 ~ 60
DF-110	Rated 110V Pump	17	<210	110-150	-15 ~ 60
DF-72-A/D	Rated 72V-A/D Pump	17	<430	100-190	-15 ~ 60
DF-110-A/D	Rated 110V-A/D Pump	17	<430	110-190	-15 ~ 60
DF-150-A/D	Rated 150V-A/D Pump	17	<430	150-220	-15 ~ 60
DF-200-A/D	Rated 200V-A/D Pump	17	<430	200-290	-15 ~ 60
DF-300-A/D	Rated 300V-A/D Pump	17	<430	300-390	-15 ~ 60
DF-380-A/D	Rated 380V-A/D Pump	17-32	<780	520-750	-15 ~ 60
DF-110-HV	Rated 110V-HV Pump	17	<430	110-190	-15 ~ 60
DF-150-HV	Rated 150V-HV Pump	17	<430	150-220	-15 ~ 60
DF-200-HV	Rated 200V-HV Pump	17	<430	200-290	-15 ~ 60
DF-300-HV	Rated 300V-HV Pump	17	<430	300-390	-15 ~ 60

TIMER FOR SOLAR PUMP

Set the startup and shutdown time to intelligently control the operation of the solar pump. Can be matched with other factory's controllers.

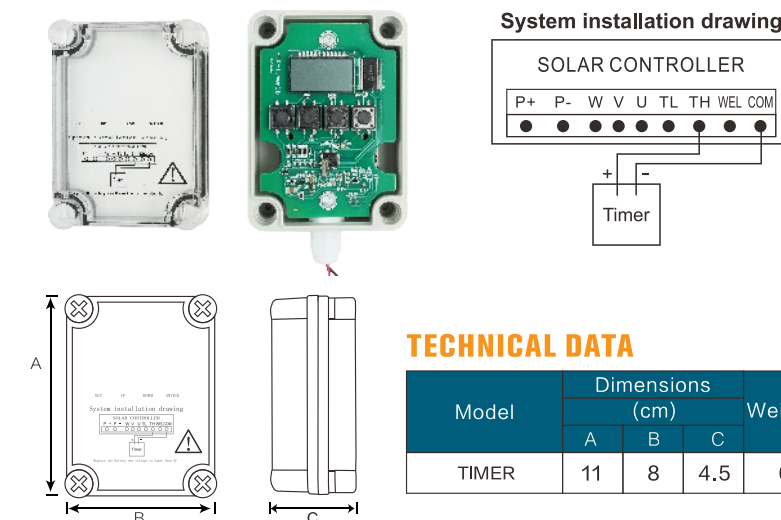

TECHNICAL DATA

Model	Dimensions (cm)			Weight(kg)
	A	B	C	
TIMER	11	8	4.5	0.25

DC SUBMERSIBLE PUMP

Environmental protection and energy saving

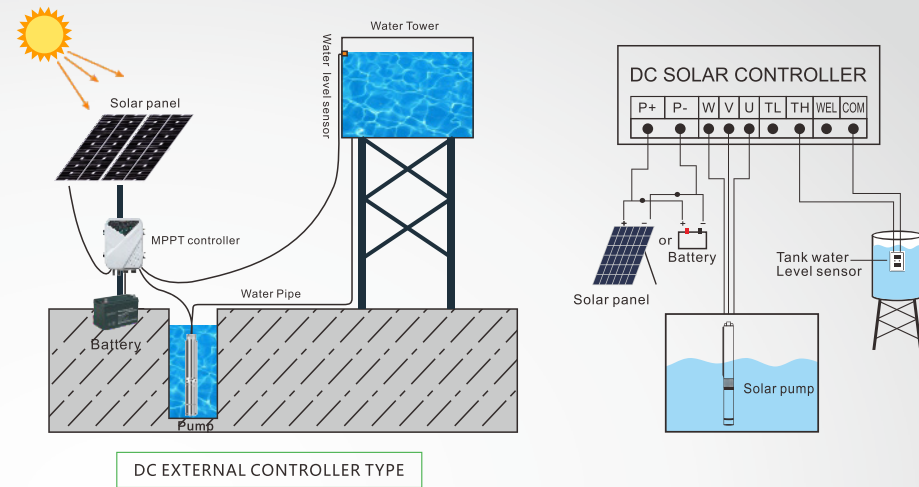

ADVANTAGE OF DC SOLAR PUMP

- 1、 Permanent magnet DC brushless synchronous motor: The efficiency is increased by 15% - 20%, saving energy consumption.
- 2、 The whole 304 stainless steel rotor shaft avoids the risk of shaft breakage.
- 3、 Brass/Stainless steel outlet/connector/ oil cylinder, with better corrosion resistance.
- 4、 Japanese NSK bearing, longer working life.
- 5、 Double bearing structure at the bottom of rotor, using angular contact bearing, can withstand greater axial pressure.
- 6、 Silicon carbide-impregnated graphite mechanical seal, long service life and reliable operation.
- 7、 180°C high temperature resistant copper wire, insulation class F.
- 8、 Cold rolled 600 silicon steel sheet stator and rotor.
- 9、 The magnet is made of 40SH NdFeb, with a temperature resistance of 150°C.
- 10、 304 S/S pump shaft.
- 11、 Controller:
 - (1)Waterproof grade: IP65
 - (2)Wide open circuit voltage range
 - (3)Ambient temperature: -15°C~60°C
 - (4)MPPT function, the solar power utilization rate is higher.
 - (5)LED displays the power, voltage, current, speed etc working condition.
 - (6)It can automatically adjust the speed for operation according to the sunlight power, and can also manually adjust the speed for operation according to the actual demand.
 - (7)Automatic startup and shutdown, without personnel on duty.
 - (8)Soft start: No impulse current, protect the pump motor.
 - (9)Over-voltage/undervoltage/over-current/phase loss/short circuit/water shortage/high temperature protection etc.
- 12、 2 years warranty.

2DPC

2"DC BRUSHLESS SOLAR PUMP WITH PLASTIC IMPELLER



DC controller

TECHNICAL DATA

ITEM	Voltage	Optimum input voltage (DC)	Power	Max. Flow	Max. Head	Outlet	Cable	Solar panel	
								Open circuit voltage(VOC)	Power
2DPC1.5-35-24-200	24V	30V-48V	200W	1.5m ³ /h	35m	0.75"	2m	<55V	≥1.3*PUMP POWER
2DPC1.7-45-24-300	24V	30V-48V	300W	1.7m ³ /h	45m	0.75"	2m	<55V	≥1.3*PUMP POWER
2DPC1.7-64-48-400	48V	60V-90V	400W	1.7m ³ /h	64m	0.75"	2m	<105V	≥1.3*PUMP POWER

HYDRAULIC PERFORMANCE CURVES

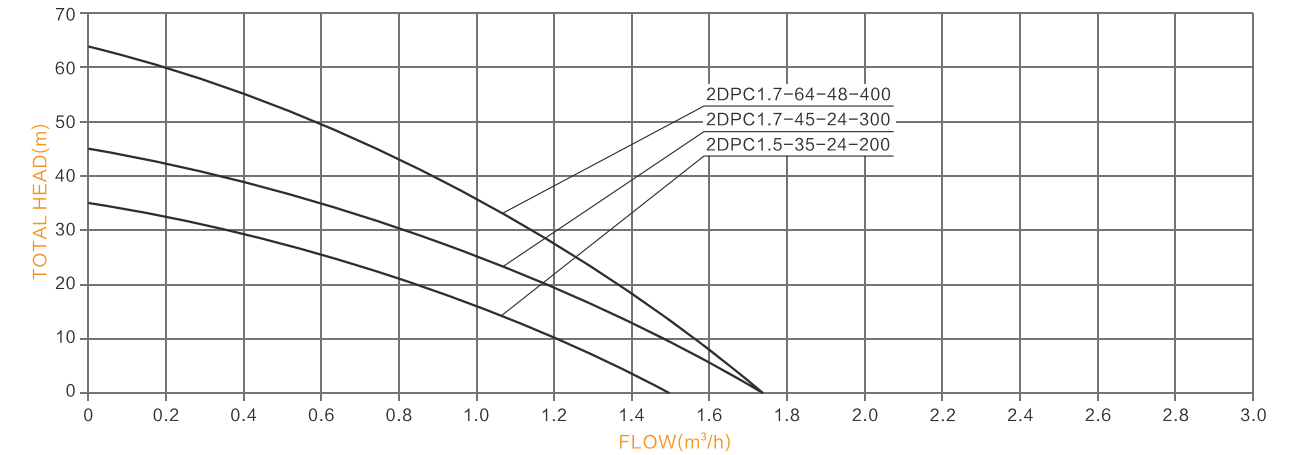

FREE SPARE PARTS



3DSS

3"DC BRUSHLESS SCREW SOLAR PUMP



DC controller

TECHNICAL DATA

ITEM	Voltage	Optimum input voltage (DC)	Power	Max. Flow	Max. Head	Outlet	Cable	Solar panel	
								Open circuit voltage(VOC)	Power
3DSS0.5-28-12-80	12V	30V-48V	80W	0.5m³/h	28m	0.75"	2m	<55V	≥ 1.3*PUMP POWER
3DSS1.2-56-24-120	24V	30V-48V	120W	1.2m³/h	56m	0.75"	2m	<55V	≥ 1.3*PUMP POWER
3DSS1.2-77-36-210	36V	30V-48V	210W	1.2m³/h	77m	0.75"	2m	<55V	≥ 1.3*PUMP POWER
3DSS1.7-109-48-500	48V	60V-90V	500W	1.7m³/h	109m	0.75"	2m	<105V	≥ 1.3*PUMP POWER
3DSS2.0-150-48-750	48V	60V-90V	750W	2.0m³/h	150m	0.75"	2m	<105V	≥ 1.3*PUMP POWER
3DSS2.0-150-72-750	72V	90V-120V	750W	2.0m³/h	150m	0.75"	2m	<160V	≥ 1.3*PUMP POWER

HYDRAULIC PERFORMANCE CURVES

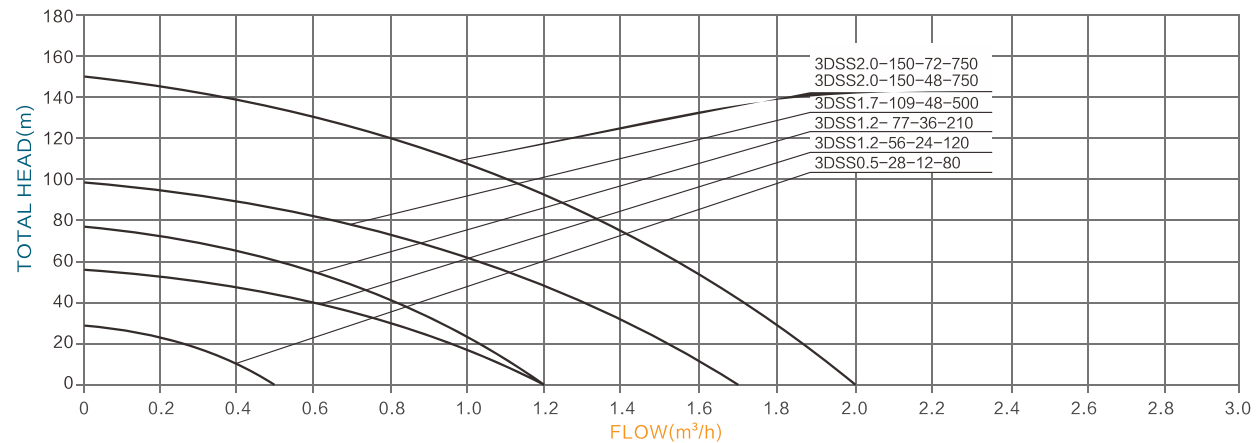

FREE SPARE PARTS



3DPC

3"DC BRUSHLESS SOLAR PUMP WITH PLASTIC IMPELLER

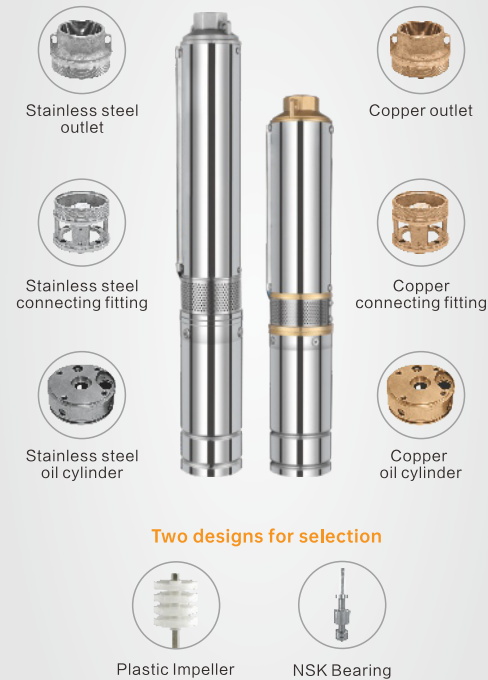

DC controller

TECHNICAL DATA

ITEM	Voltage	Optimum input voltage (DC)	Power	Max. Flow	Max. Head	Outlet	Cable	Solar panel	
								Open circuit voltage(VOC)	Power
3DPC3-25-24-200	24V	30V-48V	200W	3.0m³/h	25m	1.25"	2m	<55V	≥ 1.3*PUMP POWER
3DPC3-35-24-300	24V	30V-48V	300W	3.0m³/h	35m	1.25"	2m	<55V	≥ 1.3*PUMP POWER
3DPC3.5-47-48-400	48V	60V-90V	400W	3.5m³/h	47m	1.25"	2m	<105V	≥ 1.3*PUMP POWER
3DPC3.5-80-48-600	48V	60V-90V	600W	3.5m³/h	80m	1.25"	2m	<105V	≥ 1.3*PUMP POWER
3DPC3.5-80-72-600	72V	90V-120V	600W	3.5m³/h	80m	1.25"	2m	<160V	≥ 1.3*PUMP POWER
3DPC3.5-95-48-750	48V	60V-90V	750W	3.5m³/h	95m	1.25"	2m	<105V	≥ 1.3*PUMP POWER
3DPC3.5-95-72-750	72V	90V-120V	750W	3.5m³/h	95m	1.25"	2m	<160V	≥ 1.3*PUMP POWER
3DPC3.8-123-72-1100	72V	90V-120V	1100W	3.8m³/h	123m	1.25"	2m	<160V	≥ 1.3*PUMP POWER
3DPC3.8-123-110-1100	110V	110V-150V	1100W	3.8m³/h	123m	1.25"	2m	<210V	≥ 1.3*PUMP POWER
3DPC3.8-155-110-1300	110V	110V-150V	1300W	3.8m³/h	155m	1.25"	2m	<210V	≥ 1.3*PUMP POWER
3DPC3.8-180-110-1500	110V	110V-150V	1500W	3.8m³/h	180m	1.25"	2m	<210V	≥ 1.3*PUMP POWER

HYDRAULIC PERFORMANCE CURVES

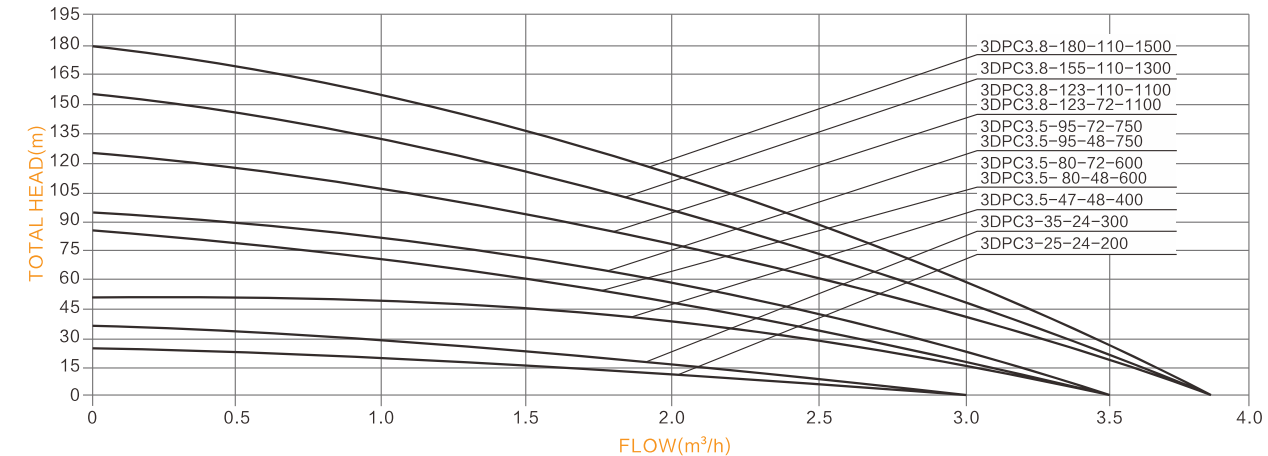

FREE SPARE PARTS

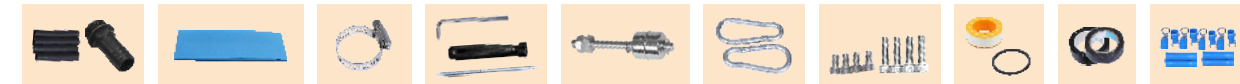

3DPC

3"DC BRUSHLESS SOLAR PUMP WITH PLASTIC IMPELLER



Two designs for selection

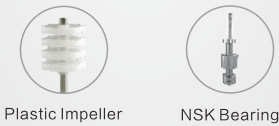

DC controller

TECHNICAL DATA

ITEM	Voltage	Optimum input voltage (DC)	Power	Max. Flow	Max. Head	Outlet	Cable	Solar panel	
								Open circuit voltage(VOC)	Power
3DPC5-45-48-500	48V	60V-90V	500W	5m³/h	45m	1.5"	2m	<105V	≥1.3*PUMP POWER
3DPC5.2-50-48-600	48V	60V-90V	600W	5.2m³/h	50m	1.5"	2m	<105V	≥1.3*PUMP POWER
3DPC5.2-50-72-600	72V	90V-120V	600W	5.2m³/h	50m	1.5"	2m	<160V	≥1.3*PUMP POWER
3DPC5.2-75-110-750	110V	110V-150V	750W	5.2m³/h	75m	1.5"	2m	<210V	≥1.3*PUMP POWER
3DPC5.5-65-72-750	72V	90V-120V	750W	5.5m³/h	65m	1.5"	2m	<160V	≥1.3*PUMP POWER
3DPC5.5-65-110-750	110V	110V-150V	750W	5.5m³/h	65m	1.5"	2m	<210V	≥1.3*PUMP POWER
3DPC6-84-110-1100	110V	110V-150V	1100W	6m³/h	84m	1.5"	2m	<210V	≥1.3*PUMP POWER
3DPC6-125-110-1500	110V	110V-150V	1500W	6m³/h	125m	1.5"	2m	<210V	≥1.3*PUMP POWER
3DPC7-46-72-750	72V	90V-120V	750W	7m³/h	46m	1.5"	2m	<160V	≥1.3*PUMP POWER
3DPC7-46-110-750	110V	110V-150V	750W	7m³/h	46m	1.5"	2m	<210V	≥1.3*PUMP POWER
3DPC7.5-62-110-1100	110V	110V-150V	1100W	7.5m³/h	62m	1.5"	2m	<210V	≥1.3*PUMP POWER
3DPC7.5-78-110-1500	110V	110V-150V	1500W	7.5m³/h	78m	1.5"	2m	<210V	≥1.3*PUMP POWER

HYDRAULIC PERFORMANCE CURVES

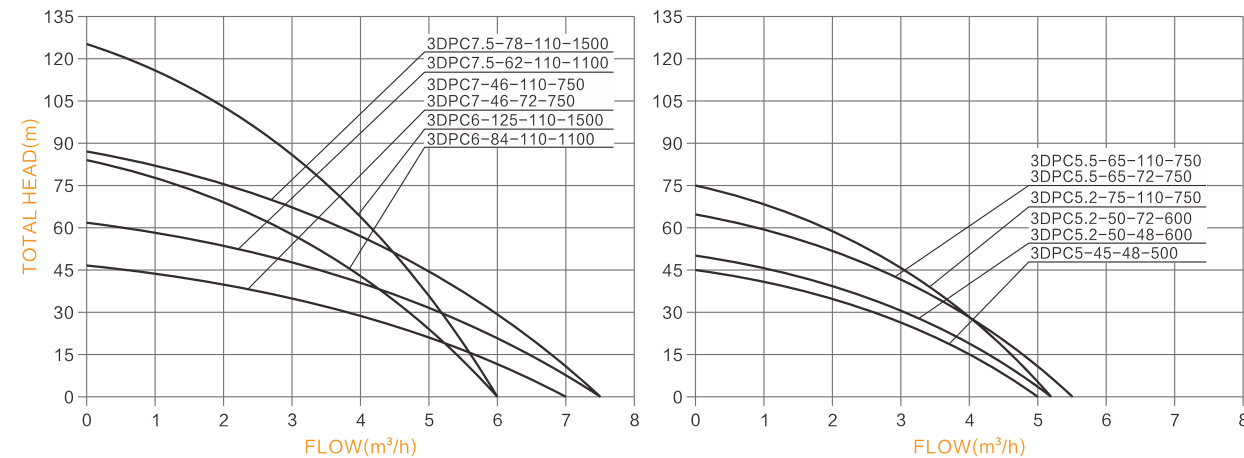

FREE SPARE PARTS



3DSC

3"DC BRUSHLESS SOLAR PUMP WITH S/S IMPELLER

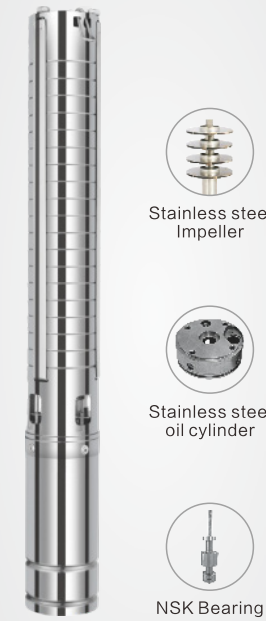

DC controller

TECHNICAL DATA

ITEM	Voltage	Optimum input voltage (DC)	Power	Max. Flow	Max. Head	Outlet	Cable	Solar panel	
								Open circuit voltage(VOC)	Power
3DSC4-35-24-300	24V	30V-48V	300W	4m³/h	35m	1.25"	2m	<55V	≥1.3*PUMP POWER
3DSC4-50-48-400	48V	60V-90V	400W	4m³/h	50m	1.25"	2m	<105V	≥1.3*PUMP POWER
3DSC4-80-48-600	48V	60V-90V	600W	4m³/h	80m	1.25"	2m	<105V	≥1.3*PUMP POWER
3DSC4.8-95-72-750	72V	90V-120V	750W	4.8m³/h	95m	1.25"	2m	<160V	≥1.3*PUMP POWER
3DSC4.8-112-72-1100	72V	90V-120V	1100W	4.8m³/h	112m	1.25"	2m	<160V	≥1.3*PUMP POWER
3DSC4.8-112-110-1100	110V	110V-150V	1100W	4.8m³/h	112m	1.25"	2m	<210V	≥1.3*PUMP POWER
3DSC4.8-135-110-1500	110V	110V-150V	1500W	4.8m³/h	135m	1.25"	2m	<210V	≥1.3*PUMP POWER

HYDRAULIC PERFORMANCE CURVES

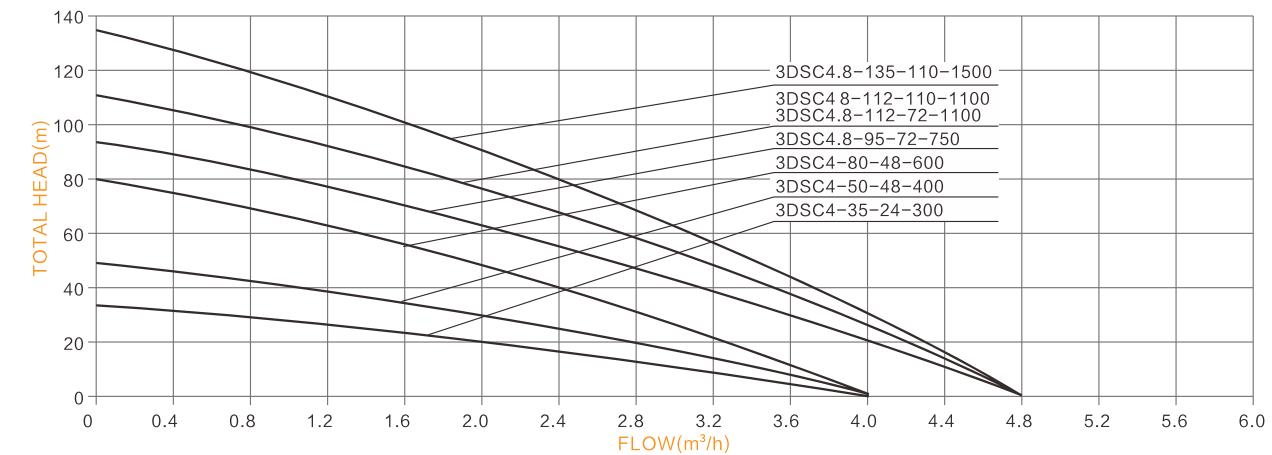

FREE SPARE PARTS



4DPC

4" DC BRUSHLESS SOLAR PUMP WITH PLASTIC IMPELLER

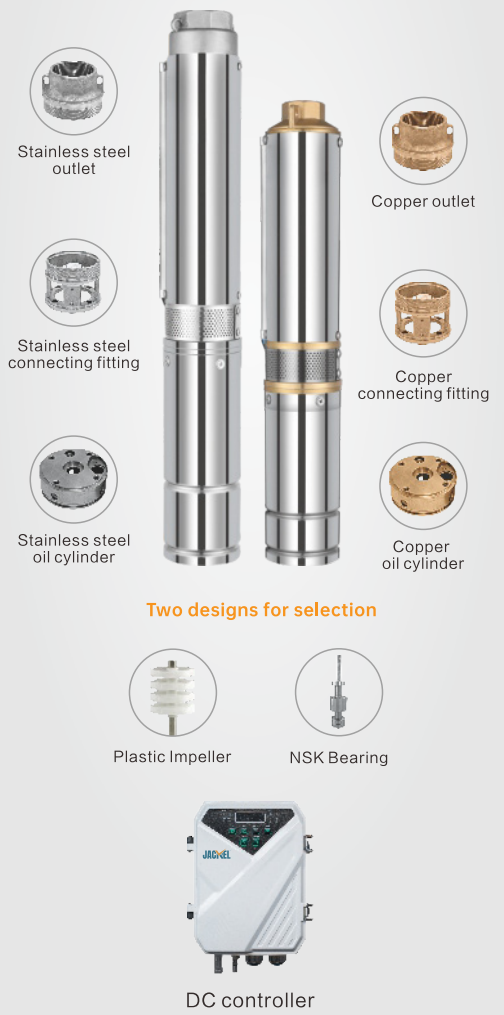

TECHNICAL DATA

ITEM	Voltage	Optimum input voltage (DC)	Power	Max. Flow	Max. Head	Outlet	Cable	Solar panel	
								Open circuit voltage(VOC)	Power
4DPC6-42-48-600	48V	60V-90V	600W	6.0m³/h	42m	1.25"	2m	<105V	≥1.3*PUMP POWER
4DPC6-42-72-600	72V	90V-120V	600W	6.0m³/h	42m	1.25"	2m	<160V	≥1.3*PUMP POWER
4DPC6-56-48-750	48V	60V-90V	750W	6.0m³/h	56m	1.25"	2m	<105V	≥1.3*PUMP POWER
4DPC6-56-72-750	72V	90V-120V	750W	6.0m³/h	56m	1.25"	2m	<160V	≥1.3*PUMP POWER
4DPC6-84-72-1100	72V	90V-120V	1100W	6.0m³/h	84m	1.25"	2m	<160V	≥1.3*PUMP POWER
4DPC6-84-110-1100	110V	110V-150V	1100W	6.0m³/h	84m	1.25"	2m	<210V	≥1.3*PUMP POWER
4DPC6-112-110-1300	110V	110V-150V	1300W	6.0m³/h	112m	1.25"	2m	<210V	≥1.3*PUMP POWER
4DPC6-135-110-1500	110V	110V-150V	1500W	6.0m³/h	135m	1.25"	2m	<210V	≥1.3*PUMP POWER

HYDRAULIC PERFORMANCE CURVES

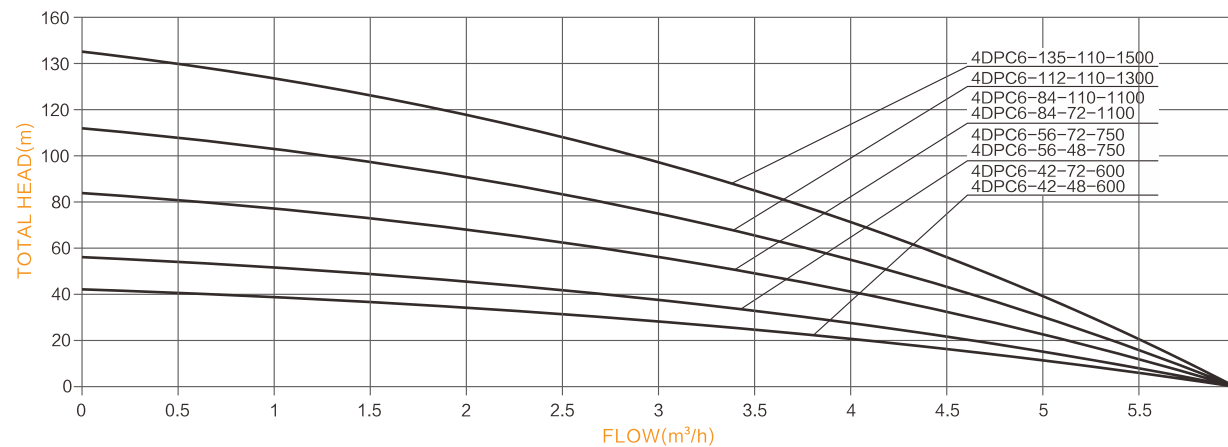

FREE SPARE PARTS



4DPC

4" DC BRUSHLESS SOLAR PUMP WITH PLASTIC IMPELLER



TECHNICAL DATA

ITEM	Voltage	Optimum input voltage (DC)	Power	Max. Flow	Max. Head	Outlet	Cable	Solar panel	
								Open circuit voltage(VOC)	Power
4DPC9-45-110-750	110V	110V-150V	750W	9.0m³/h	45m	2"	2m	<210V	≥1.3*PUMP POWER
4DPC9-58-110-1100	110V	110V-150V	1100W	9.0m³/h	58m	2"	2m	<210V	≥1.3*PUMP POWER
4DPC9-71-110-1300	110V	110V-150V	1300W	9.0m³/h	71m	2"	2m	<210V	≥1.3*PUMP POWER
4DPC9-85-110-1500	110V	110V-150V	1500W	9.0m³/h	85m	2"	2m	<210V	≥1.3*PUMP POWER
4DPC13-36-110-750	110V	110V-150V	750W	13.0m³/h	36m	2"	2m	<210V	≥1.3*PUMP POWER
4DPC13-49-110-1100	110V	110V-150V	1100W	13.0m³/h	49m	2"	2m	<210V	≥1.3*PUMP POWER
4DPC13-54-110-1300	110V	110V-150V	1300W	13.0m³/h	54m	2"	2m	<210V	≥1.3*PUMP POWER
4DPC13-60-110-1500	110V	110V-150V	1500W	13.0m³/h	60m	2"	2m	<210V	≥1.3*PUMP POWER
4DPC17-48-110-1500	110V	110V-150V	1500W	17.0m³/h	48m	2"	2m	<210V	≥1.3*PUMP POWER

HYDRAULIC PERFORMANCE CURVES

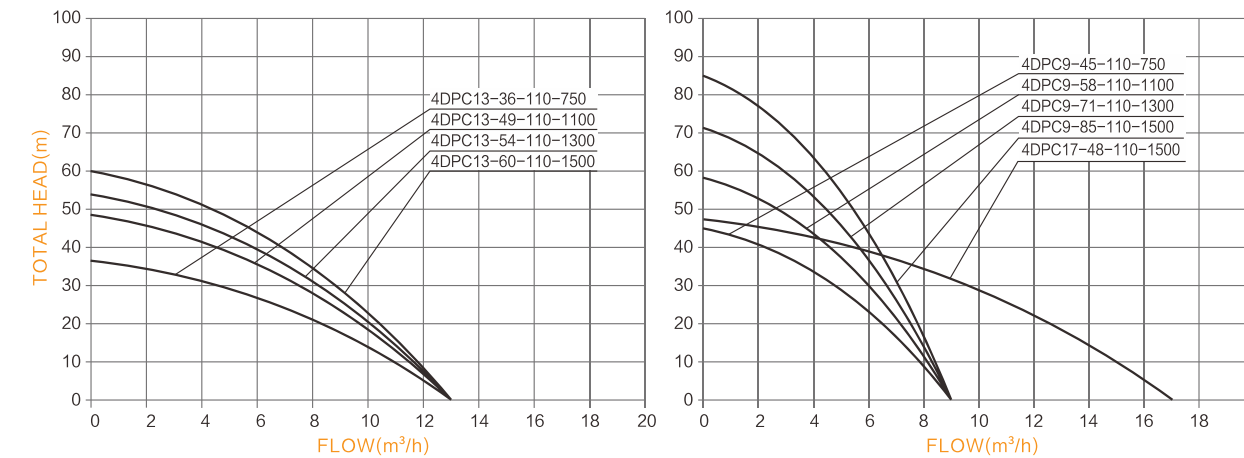

FREE SPARE PARTS



4DLR

4"DC BRUSHLESS SOLAR PUMP WITH PLASTIC IMPELLER



TECHNICAL DATA

ITEM	Voltage	Optimum input voltage (DC)	Power	Max. Flow	Max. Head	Outlet	Cable	Solar panel	
								Open circuit voltage(VOC)	Power
4DLR5-85-110-750	110V	110V-150V	750W	5m³/h	85m	1.25"	2m	<210V	≥1.3*PUMP POWER
4DLR6-65-72-550	72V	90V-120V	550W	6m³/h	65m	1.25"	2m	<160V	≥1.3*PUMP POWER
4DLR7.5-65-110-750	110V	110V-150V	750W	7.5m³/h	65m	2"	2m	<210V	≥1.3*PUMP POWER
4DLR7.5-100-72-1100	72V	90V-120V	1100W	7.5m³/h	100m	2"	2m	<160V	≥1.3*PUMP POWER
4DLR7.5-110-110-1500	110V	110V-150V	1500W	7.5m³/h	110m	2"	2m	<210V	≥1.3*PUMP POWER
4DLR11-45-72-550	72V	90V-120V	550W	11m³/h	45m	2"	2m	<160V	≥1.3*PUMP POWER
4DLR12-75-72-1100	72V	90V-120V	1100W	12m³/h	75m	2"	2m	<160V	≥1.3*PUMP POWER
4DLR11.5-100-110-1500	110V	110V-150V	1500W	11.5m³/h	100m	2"	2m	<210V	≥1.3*PUMP POWER
4DLR14.5-45-110-750	110V	110V-150V	750W	14.5m³/h	45m	2"	2m	<210V	≥1.3*PUMP POWER
4DLR15-55-72-1100	72V	90V-120V	1100W	15m³/h	55m	2"	2m	<160V	≥1.3*PUMP POWER
4DLR15.5-65-110-1500	110V	110V-150V	1500W	15.5m³/h	65m	2"	2m	<210V	≥1.3*PUMP POWER
4DLR20-38-110-1500	110V	110V-150V	1500W	20m³/h	38m	2"	2m	<210V	≥1.3*PUMP POWER

HYDRAULIC PERFORMANCE CURVES

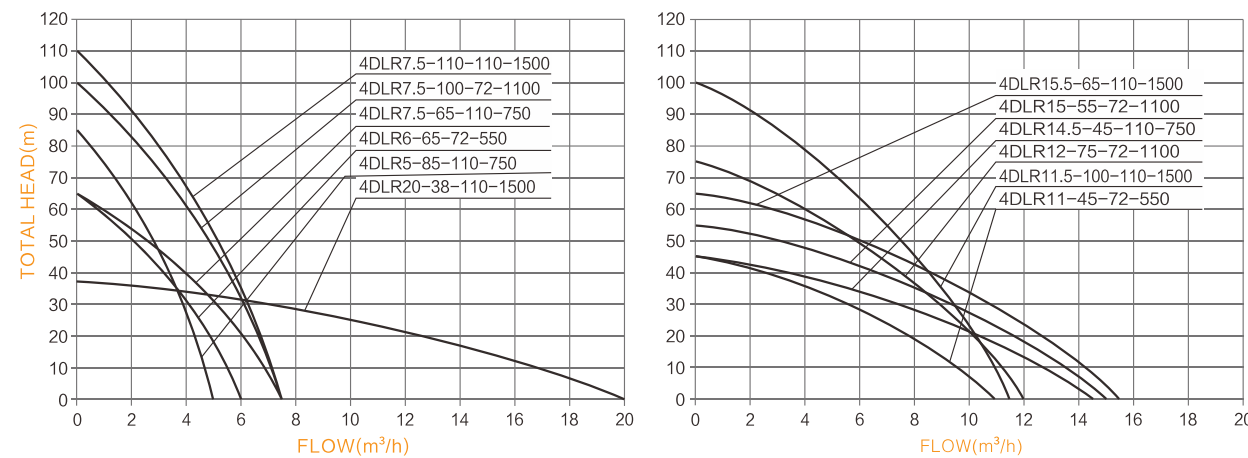

FREE SPARE PARTS



4DSC

4"DC BRUSHLESS SOLAR PUMP WITH S/S IMPELLER



TECHNICAL DATA

ITEM	Voltage	Optimum input voltage (DC)	Power	Max. Flow	Max. Head	Outlet	Cable	Solar panel	
								Open circuit voltage(VOC)	Power
4DSC5.2-45-48-500	48V	60V-90V	500W	5.2m³/h	45m	1.25"	2m	<105V	≥1.3*PUMP POWER
4DSC5.2-67-48-750	48V	60V-90V	750W	5.2m³/h	67m	1.25"	2m	<105V	≥1.3*PUMP POWER
4DSC5.2-67-72-750	72V	90V-120V	750W	5.2m³/h	67m	1.25"	2m	<160V	≥1.3*PUMP POWER
4DSC5.2-101-72-1100	72V	90V-120V	1100W	5.2m³/h	101m	1.25"	2m	<160V	≥1.3*PUMP POWER
4DSC5.2-101-110-1100	110V	110V-150V	1100W	5.2m³/h	101m	1.25"	2m	<210V	≥1.3*PUMP POWER
4DSC5.2-146-110-1300	110V	110V-150V	1300W	5.2m³/h	146m	1.25"	2m	<210V	≥1.3*PUMP POWER
4DSC4.8-203-110-1500	110V	110V-150V	1500W	4.8m³/h	203m	1.25"	2m	<210V	≥1.3*PUMP POWER
4DSC7.5-80-110-1300	110V	110V-150V	1300W	7.5m³/h	80m	1.25"	2m	<210V	≥1.3*PUMP POWER
4DSC7.5-100-110-1500	110V	110V-150V	1500W	7.5m³/h	100m	1.25"	2m	<210V	≥1.3*PUMP POWER

HYDRAULIC PERFORMANCE CURVES

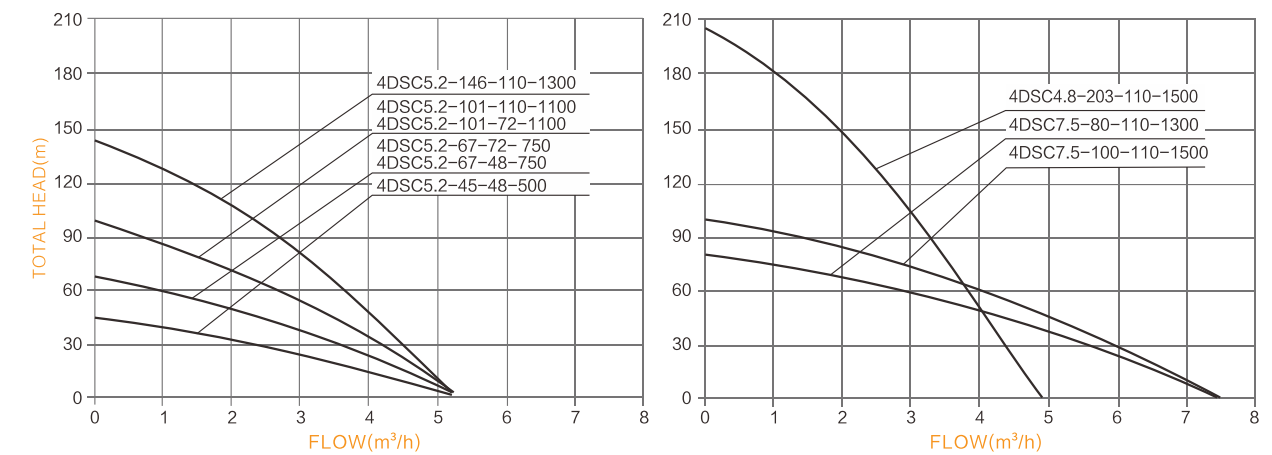

FREE SPARE PARTS



4DSC/4/6DSC

4" /6" DC BRUSHLESS SOLAR PUMP WITH S/S IMPELLER

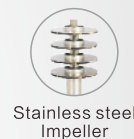

Stainless steel Impeller



Stainless steel oil cylinder



NSK Bearing



DC controller

TECHNICAL DATA

ITEM	Voltage	Optimum input voltage (DC)	Power	Max. Flow	Max. Head	Outlet	Cable	Solar panel	
								Open circuit voltage(VOC)	Power
4DSC11-60-110-1500	110V	110V-150V	1500W	11m³/h	60m	2"	2m	<210V	≥ 1.3*PUMP POWER
4DSC19-35-110-1500	110V	110V-150V	1500W	19m³/h	35m	2"	2m	<210V	≥ 1.3*PUMP POWER
4DSC25-26-110-1500	110V	110V-150V	1500W	25m³/h	26m	2"	2m	<210V	≥ 1.3*PUMP POWER
4/6DSC30-19-72-1100	72V	90V-120V	1100W	30m³/h	19m	3"	2m	<160V	≥ 1.3*PUMP POWER
4/6DSC36-22-110-1500	110V	110V-150V	1500W	36m³/h	22m	3"	2m	<210V	≥ 1.3*PUMP POWER
4/6DSC30-31-110-1500	110V	110V-150V	1500W	30m³/h	31m	3"	2m	<210V	≥ 1.3*PUMP POWER

HYDRAULIC PERFORMANCE CURVES

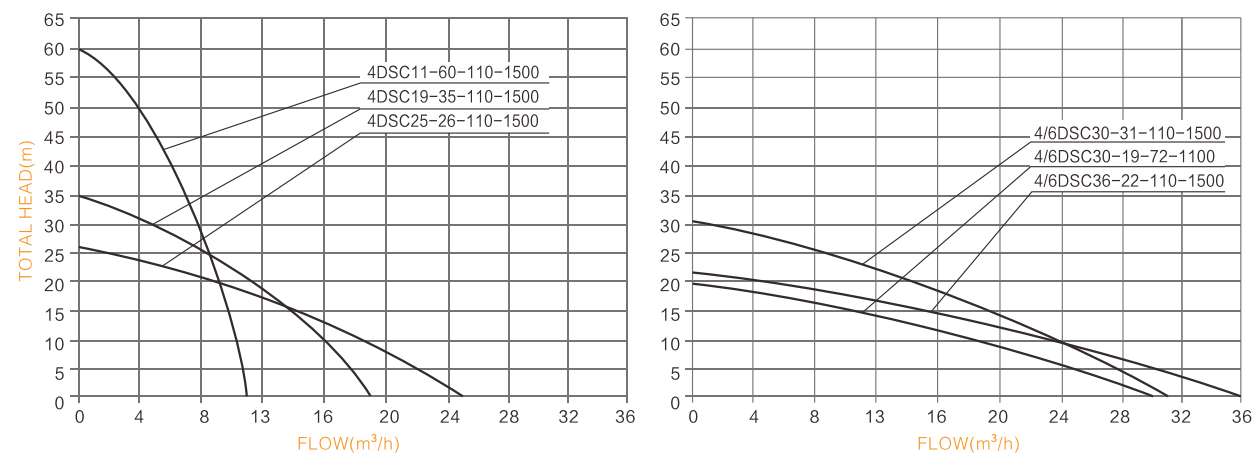

FREE SPARE PARTS



AC/DC HYBRID & WIDE VOLTAGE SUBMERSIBLE PUMP

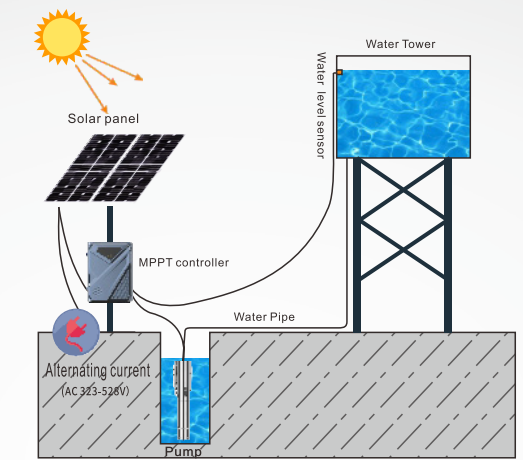

AC/DC EXTERNAL CONTROLLER TYPE

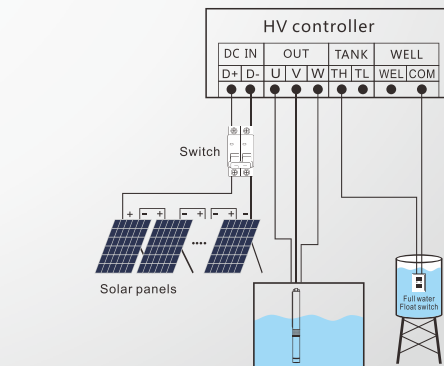
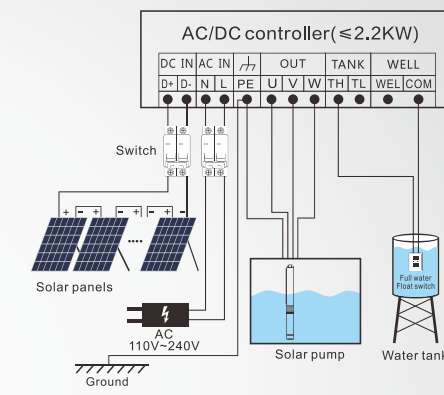
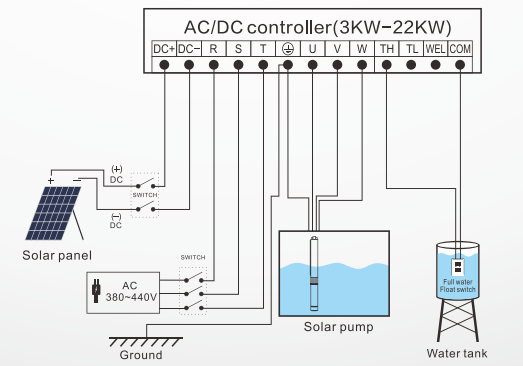

3DPC-A/D 3DPC-HV

3" AC/DC & WIDE VOLTAGE BRUSHLESS SOLAR PUMP WITH PLASTIC IMPELLER



Two designs for selection

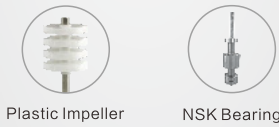

AC/DC auto-switching controller (≤2.2KW)

Wide Voltage HV Controller

TECHNICAL DATA

ITEM	(AC) Voltage	(DC) Voltage	Power	Max. Flow	Max. Head	Outlet	Cable	Solar panel	
								Open circuit voltage(VOC)	Power
3DPC3.5-95-110-750-A/D 3DPC3.5-95-110-750-HV	85V-280V /	80V-430V	750W	3.5m³/h	95m	1.25"	2m	<430V	≥1.3*PUMP POWER
3DPC3.8-123-150-1100-A/D 3DPC3.8-123-150-1100-HV	85V-280V /	80V-430V	1100W	3.8m³/h	123m	1.25"	2m	<430V	≥1.3*PUMP POWER
3DPC3.8-155-150-1300-A/D 3DPC3.8-155-150-1300-HV	85V-280V /	80V-430V	1300W	3.8m³/h	155m	1.25"	2m	<430V	≥1.3*PUMP POWER
3DPC3.8-180-200-1500-A/D 3DPC3.8-180-200-1500-HV	85V-280V /	80V-430V	1500W	3.8m³/h	180m	1.25"	2m	<430V	≥1.3*PUMP POWER
3DPC5.2-75-110-750-A/D 3DPC5.2-75-110-750-HV	85V-280V /	80V-430V	750W	5.2m³/h	75m	1.5"	2m	<430V	≥1.3*PUMP POWER
3DPC5.5-65-110-750-A/D 3DPC5.5-65-110-750-HV	85V-280V /	80V-430V	750W	5.5m³/h	65m	1.5"	2m	<430V	≥1.3*PUMP POWER
3DPC6-84-150-1100-A/D 3DPC6-84-150-1100-HV	85V-280V /	80V-430V	1100W	6m³/h	84m	1.5"	2m	<430V	≥1.3*PUMP POWER
3DPC6-125-200-1500-A/D 3DPC6-125-200-1500-HV	85V-280V /	80V-430V	1500W	6m³/h	125m	1.5"	2m	<430V	≥1.3*PUMP POWER
3DPC7-46-110-750-A/D 3DPC7-46-110-750-HV	85V-280V /	80V-430V	750W	7m³/h	46m	1.5"	2m	<430V	≥1.3*PUMP POWER
3DPC7.5-62-150-1100-A/D 3DPC7.5-62-150-1100-HV	85V-280V /	80V-430V	1100W	7.5m³/h	62m	1.5"	2m	<430V	≥1.3*PUMP POWER
3DPC7.5-78-200-1500-A/D 3DPC7.5-78-200-1500-HV	85V-280V /	80V-430V	1500W	7.5m³/h	78m	1.5"	2m	<430V	≥1.3*PUMP POWER

PERFORMANCE CURVES

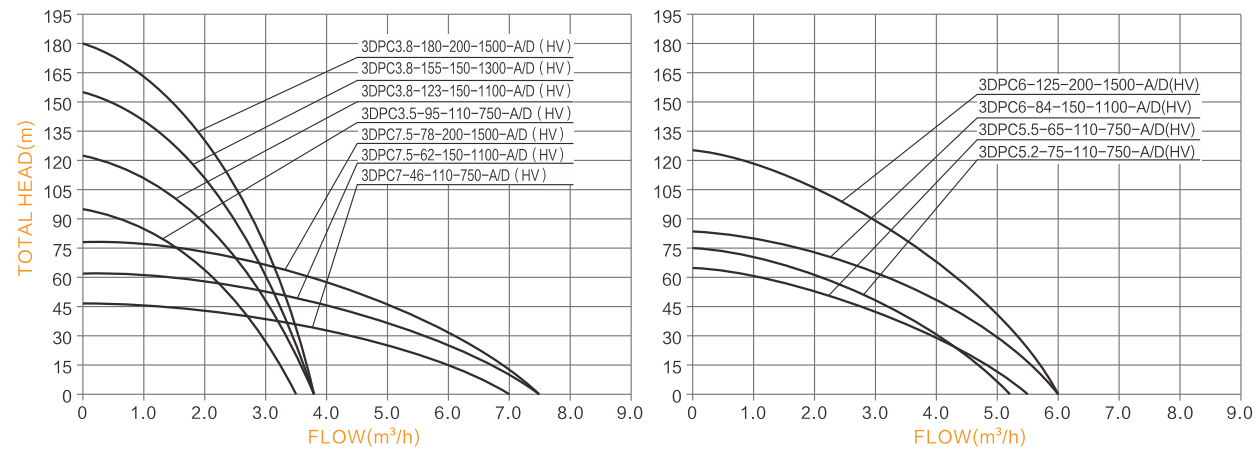

FREE SPARE PARTS

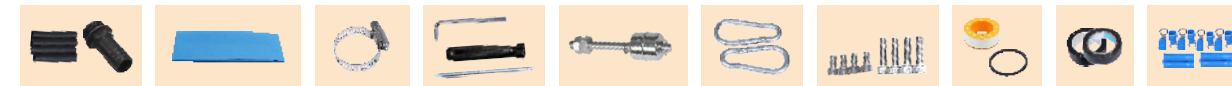

3DSC-A/D 3DSC-HV

3" AC/DC & WIDE VOLTAGE BRUSHLESS SOLAR PUMP WITH S/S IMPELLER

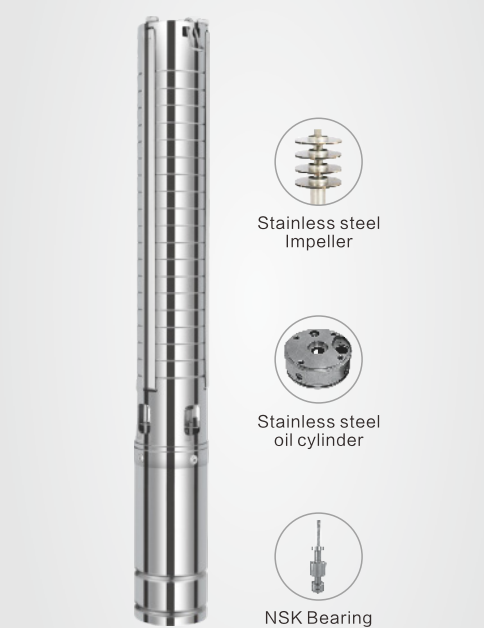

AC/DC auto-switching controller (≤2.2KW)

Wide Voltage HV Controller

TECHNICAL DATA

ITEM	(AC) Voltage	(DC) Voltage	Power	Max. Flow	Max. Head	Outlet	Cable	Solar panel	
								Open circuit voltage(VOC)	Power
3DSC4.8-95-110-750-A/D 3DSC4.8-95-110-750-HV	85V-280V /	80V-430V	750W	4.8m³/h	95m	1.25"	2m	<430V	≥1.3*PUMP POWER
3DSC4.8-110-150-1100-A/D 3DSC4.8-110-150-1100-HV	85V-280V /	80V-430V	1100W	4.8m³/h	110m	1.25"	2m	<430V	≥1.3*PUMP POWER
3DSC4.8-130-200-1500-A/D 3DSC4.8-130-200-1500-HV	85V-280V /	80V-430V	1500W	4.8m³/h	130m	1.25"	2m	<430V	≥1.3*PUMP POWER

HYDRAULIC PERFORMANCE CURVES

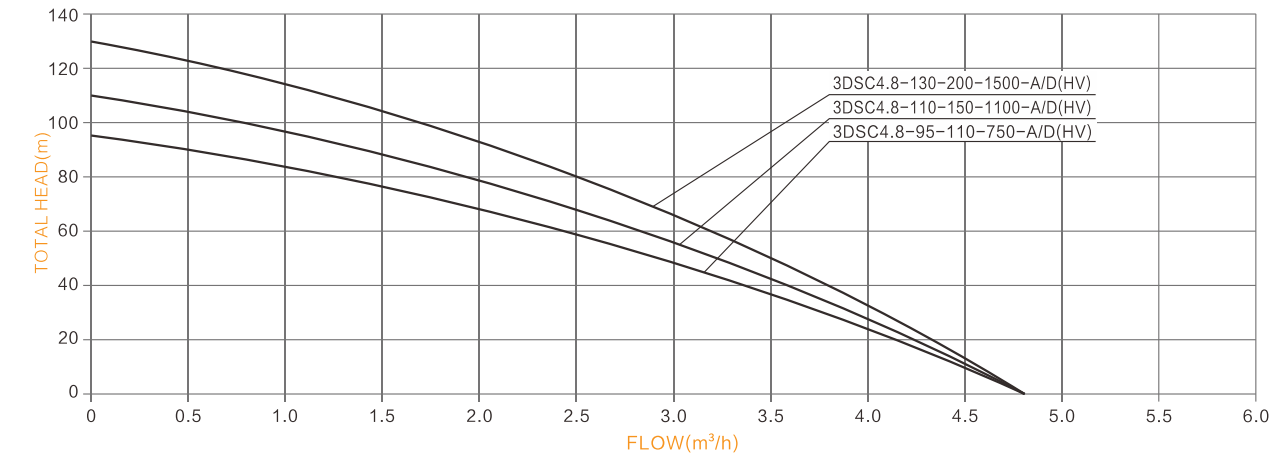

FREE SPARE PARTS



4DPC-A/D 4DPC-HV

4" AC/DC & WIDE VOLTAGE BRUSHLESS SOLAR PUMP WITH PLASTIC IMPELLER



Two designs for selection



AC/DC auto-switching controller (≤2.2KW)
Wide Voltage HV Controller

TECHNICAL DATA

ITEM	(AC) Voltage	(DC) Voltage	Power	Max. Flow	Max. Head	Outlet	Cable	Solar panel	
								Open circuit voltage(VOC)	Power
4DPC6-56-110-750-A/D	85V-280V	80V-430V	750W	6m³/h	56m	1.25"	2m	<430V	≥1.3*PUMP POWER
4DPC6-56-110-750-HV	/	/	/	/	/	/	/	/	/
4DPC6-84-150-1100-A/D	85V-280V	80V-430V	1100W	6m³/h	84m	1.25"	2m	<430V	≥1.3*PUMP POWER
4DPC6-84-150-1100-HV	/	/	/	/	/	/	/	/	/
4DPC6-112-150-1300-A/D	85V-280V	80V-430V	1300W	6m³/h	112m	1.25"	2m	<430V	≥1.3*PUMP POWER
4DPC6-112-150-1300-HV	/	/	/	/	/	/	/	/	/
4DPC6-135-200-1500-A/D	85V-280V	80V-430V	1500W	6m³/h	135m	1.25"	2m	<430V	≥1.3*PUMP POWER
4DPC6-135-200-1500-HV	/	/	/	/	/	/	/	/	/
4DPC9-45-110-750-A/D	85V-280V	80V-430V	750W	9m³/h	45m	2"	2m	<430V	≥1.3*PUMP POWER
4DPC9-45-110-750-HV	/	/	/	/	/	/	/	/	/
4DPC9-58-150-1100-A/D	85V-280V	80V-430V	1100W	9m³/h	58m	2"	2m	<430V	≥1.3*PUMP POWER
4DPC9-58-150-1100-HV	/	/	/	/	/	/	/	/	/
4DPC9-71-150-1300-A/D	85V-280V	80V-430V	1300W	9m³/h	71m	2"	2m	<430V	≥1.3*PUMP POWER
4DPC9-71-150-1300-HV	/	/	/	/	/	/	/	/	/
4DPC9-85-200-1500-A/D	85V-280V	80V-430V	1500W	9m³/h	85m	2"	2m	<430V	≥1.3*PUMP POWER
4DPC9-85-200-1500-HV	/	/	/	/	/	/	/	/	/
4DPC13-36-110-750-A/D	85V-280V	80V-430V	750W	13m³/h	36m	2"	2m	<430V	≥1.3*PUMP POWER
4DPC13-36-110-750-HV	/	/	/	/	/	/	/	/	/
4DPC13-49-150-1100-A/D	85V-280V	80V-430V	1100W	13m³/h	49m	2"	2m	<430V	≥1.3*PUMP POWER
4DPC13-49-150-1100-HV	/	/	/	/	/	/	/	/	/
4DPC13-54-150-1300-A/D	85V-280V	80V-420V	1300W	13m³/h	54m	2"	2m	<430V	≥1.3*PUMP POWER
4DPC13-54-150-1300-HV	/	/	/	/	/	/	/	/	/
4DPC13-60-200-1500-A/D	85V-280V	80V-430V	1500W	13m³/h	60m	2"	2m	<430V	≥1.3*PUMP POWER
4DPC13-60-200-1500-HV	/	/	/	/	/	/	/	/	/
4DPC17-48-200-1500-A/D	85V-280V	80V-430V	1500W	17m³/h	48m	2"	2m	<430V	≥1.3*PUMP POWER
4DPC17-48-200-1500-HV	/	/	/	/	/	/	/	/	/

PERFORMANCE CURVES

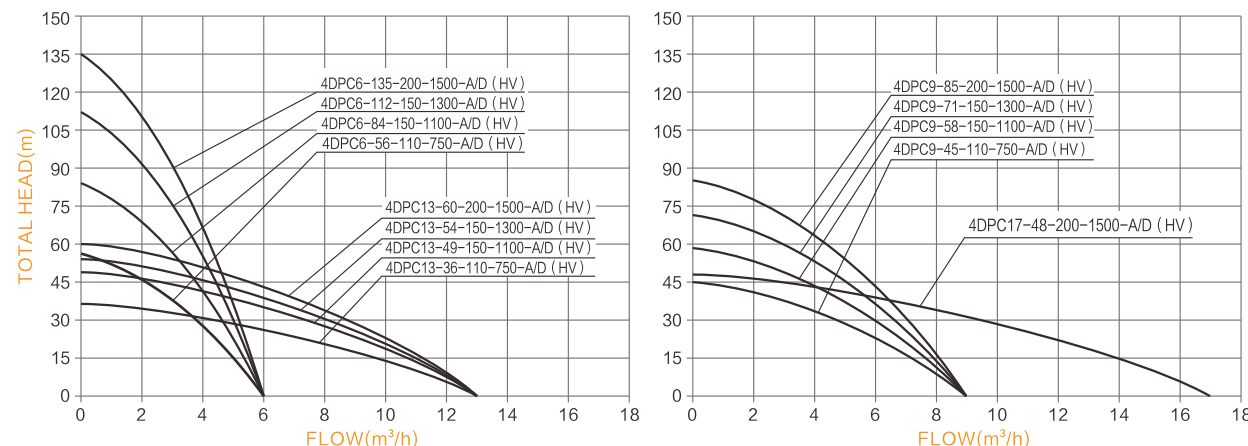

FREE SPARE PARTS



4DLR-A/D 4DLR-HV

4" AC/DC & WIDE VOLTAGE BRUSHLESS SOLAR PUMP WITH PLASTIC IMPELLER

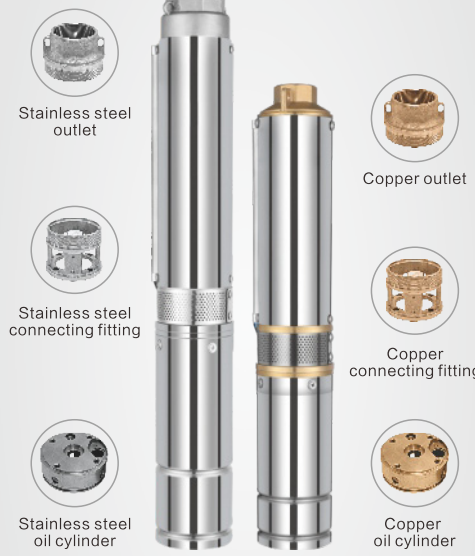

Two designs for selection

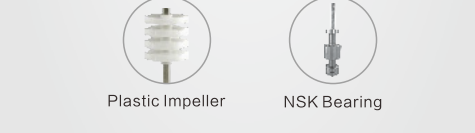

AC/DC auto-switching controller (≤2.2KW)
Wide Voltage HV Controller

TECHNICAL DATA

ITEM	(AC) Voltage	(DC) Voltage	Power	Max. Flow	Max. Head	Outlet	Cable	Solar panel	
								Open circuit voltage(VOC)	Power
4DLR4.5-85-110-750-A/D	85V-280V	80V-430V	750W	4.5m³/h	85m	1.25"	2m	<430V	≥1.3*PUMP POWER
4DLR4.5-85-110-750-HV	/	/	/	/	/	/	/	/	/
4DLR7.5-65-110-750-A/D	85V-280V	80V-430V	750W	7.5m³/h	65m	2"	2m	<430V	≥1.3*PUMP POWER
4DLR7.5-65-110-750-HV	/	/	/	/	/	/	/	/	/
4DLR7.5-100-150-1100-A/D	85V-280V	80V-430V	1100W	7.5m³/h	100m	2"	2m	<430V	≥1.3*PUMP POWER
4DLR7.5-100-150-1100-HV	/	/	/	/	/	/	/	/	/
4DLR7.5-110-200-1500-A/D	85V-280V	80V-430V	1500W	7.5m³/h	110m	2"	2m	<430V	≥1.3*PUMP POWER
4DLR7.5-110-200-1500-HV	/	/	/	/	/	/	/	/	/
4DLR12-75-150-1100-A/D	85V-280V	80V-430V	1100W	12m³/h	75m	2"	2m	<430V	≥1.3*PUMP POWER
4DLR12-75-150-1100-HV	/	/	/	/	/	/	/	/	/
4DLR11.5-100-200-1500-A/D	85V-280V	80V-430V	1500W	11.5m³/h	100m	2"	2m	<430V	≥1.3*PUMP POWER
4DLR11.5-100-200-1500-HV	/	/	/	/	/	/	/	/	/
4DLR14.5-45-110-750-A/D	85V-280V	80V-430V	750W	14.5m³/h	45m	2"	2m	<430V	≥1.3*PUMP POWER
4DLR14.5-45-110-750-HV	/	/	/	/	/	/	/	/	/
4DLR15-55-150-1100-A/D	85V-280V	80V-430V	1100W	15m³/h	55m	2"	2m	<430V	≥1.3*PUMP POWER
4DLR15-55-150-1100-HV	/	/	/	/	/	/	/	/	/
4DLR15.5-70-200-1500-A/D	85V-280V	80V-430V	1500W	15.5m³/h	70m	2"	2m	<430V	≥1.3*PUMP POWER
4DLR15.5-70-200-1500-HV	/	/	/	/	/	/	/	/	/
4DLR17-95-300-2200-A/D	85V-280V	80V-430V	2200W	17m³/h	95m	2"	2m	<430V	≥1.3*PUMP POWER
4DLR17-95-300-2200-HV	/	/	/	/	/	/	/	/	/
4DLR20-45-200-1500-A/D	85V-280V	80V-430V	1500W	20m³/h	45m	2"	2m	<430V	≥1.3*PUMP POWER
4DLR20-45-200-1500-HV	/	/	/	/	/	/	/	/	/
4DLR22-70-300-2200-A/D	85V-280V	80V-430V	2200W	22m³/h	70m	2"	2m	<430V	≥1.3*PUMP POWER
4DLR22-70-300-2200-HV	/	/	/	/	/	/	/	/	/

HYDRAULIC PERFORMANCE CURVES

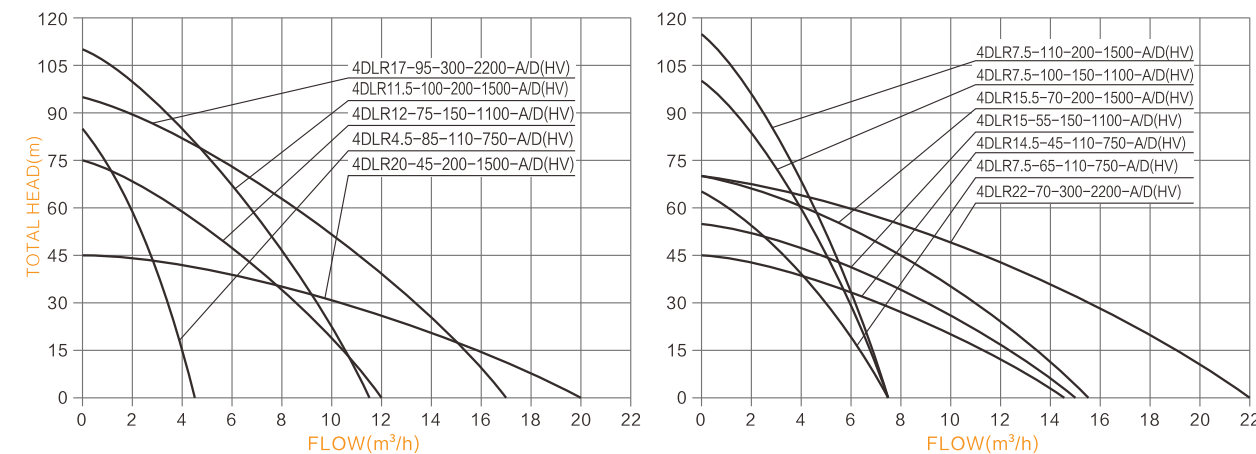

FREE SPARE PARTS



4DPC-A/D 4DPC-HV

4" AC/DC & WIDE VOLTAGE BRUSHLESS SOLAR PUMP WITH PLASTIC IMPELLER



Two designs for selection



AC/DC auto-switching controller (≤2.2KW)

Wide Voltage HV Controller

TECHNICAL DATA

ITEM	(AC) Voltage	(DC) Voltage	Power	Max. Flow	Max. Head	Outlet	Cable	Solar panel	
								Open circuit voltage(VOC)	Power
4DPC6-175-300-2200-A/D	85V-280V	80V-430V	2200W	6m³/h	175m	1.25"	2m	<430V	≥1.3*PUMP POWER
4DPC6-175-300-2200-HV	/	/	/	/	/	/	/	/	/
4DPC9.5-125-300-2200-A/D	85V-280V	80V-430V	2200W	9.5m³/h	125m	2"	2m	<430V	≥1.3*PUMP POWER
4DPC9.5-125-300-2200-HV	/	/	/	/	/	/	/	/	/
4DPC13-110-300-2200-A/D	85V-280V	80V-430V	2200W	13m³/h	110m	2"	2m	<430V	≥1.3*PUMP POWER
4DPC13-110-300-2200-HV	/	/	/	/	/	/	/	/	/

HYDRAULIC PERFORMANCE CURVES

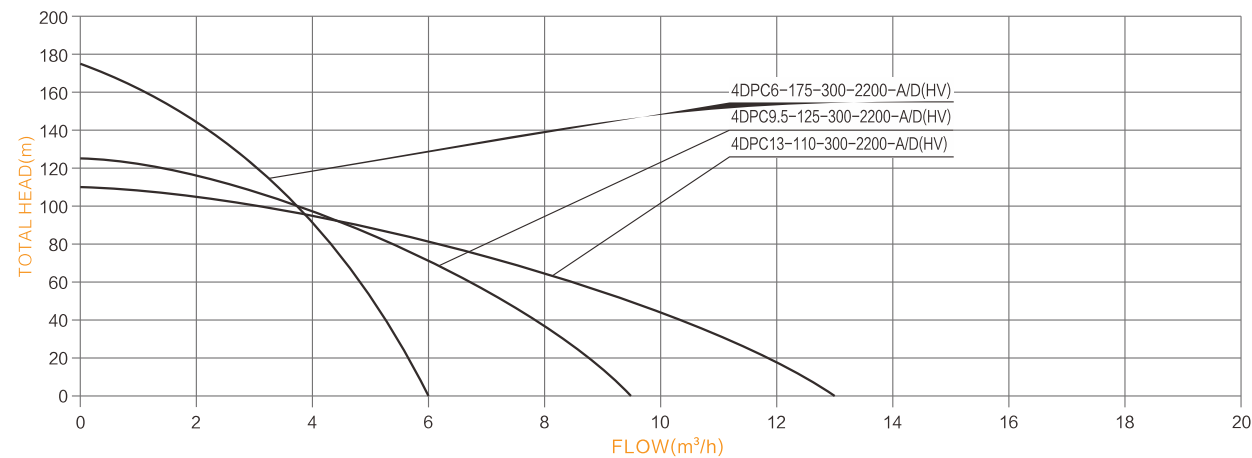

FREE SPARE PARTS



4DSC-A/D 4DSC-HV

4" AC/DC & WIDE VOLTAGE BRUSHLESS SOLAR PUMP WITH S/S IMPELLER



AC/DC auto-switching controller (≤2.2KW)

Wide Voltage HV Controller

TECHNICAL DATA

ITEM	(AC) Voltage	(DC) Voltage	Power	Max. Flow	Max. Head	Outlet	Cable	Solar panel	
								Open circuit voltage(VOC)	Power
4DSC5.2-67-110-750-A/D	85V-280V	80V-430V	750W	5.2m³/h	67m	1.25"	2m	<430V	≥1.3*PUMP POWER
4DSC5.2-67-110-750-HV	/	/	/	/	/	/	/	/	/
4DSC4.8-203-200-1500-A/D	85V-280V	80V-430V	1500W	4.8m³/h	203m	1.25"	2m	<430V	≥1.3*PUMP POWER
4DSC4.8-203-200-1500-HV	/	/	/	/	/	/	/	/	/
4DSC5.2-101-150-1100-A/D	85V-280V	80V-430V	1100W	5.2m³/h	101m	1.25"	2m	<430V	≥1.3*PUMP POWER
4DSC5.2-101-150-1100-HV	/	/	/	/	/	/	/	/	/
4DSC5.2-146-200-1300-A/D	85V-280V	80V-430V	1300W	5.2m³/h	146m	1.25"	2m	<430V	≥1.3*PUMP POWER
4DSC5.2-146-200-1300-HV	/	/	/	/	/	/	/	/	/
4DSC7.5-80-150-1300-A/D	85V-280V	80V-430V	1300W	7.5m³/h	80m	1.25"	2m	<430V	≥1.3*PUMP POWER
4DSC7.5-80-150-1300-HV	/	/	/	/	/	/	/	/	/
4DSC7.5-100-200-1500-A/D	85V-280V	80V-430V	1500W	7.5m³/h	100m	1.25"	2m	<430V	≥1.3*PUMP POWER
4DSC7.5-100-200-1500-HV	/	/	/	/	/	/	/	/	/
4DSC11-60-200-1500-A/D	85V-280V	80V-430V	1500W	11m³/h	60m	2"	2m	<430V	≥1.3*PUMP POWER
4DSC11-60-200-1500-HV	/	/	/	/	/	/	/	/	/
4DSC19-35-200-1500-A/D	85V-280V	80V-430V	1500W	19m³/h	35m	2"	2m	<430V	≥1.3*PUMP POWER
4DSC19-35-200-1500-HV	/	/	/	/	/	/	/	/	/
4DSC25-26-200-1500-A/D	85V-280V	80V-430V	1500W	25m³/h	26m	2"	2m	<430V	≥1.3*PUMP POWER
4DSC25-26-200-1500-HV	/	/	/	/	/	/	/	/	/
4/6DSC30-19-150-1100-A/D	85V-280V	80V-430V	1100W	30m³/h	19m	3"	2m	<430V	≥1.3*PUMP POWER
4/6DSC30-19-150-1100-HV	/	/	/	/	/	/	/	/	/
4/6DSC36-22-200-1500-A/D	85V-280V	80V-430V	1500W	36m³/h	22m	3"	2m	<430V	≥1.3*PUMP POWER
4/6DSC36-22-200-1500-HV	/	/	/	/	/	/	/	/	/
4/6DSC30-31-200-1500-A/D	85V-280V	80V-430V	1500W	30m³/h	31m	3"	2m	<430V	≥1.3*PUMP POWER
4/6DSC30-31-200-1500-HV	/	/	/	/	/	/	/	/	/

HYDRAULIC PERFORMANCE CURVES

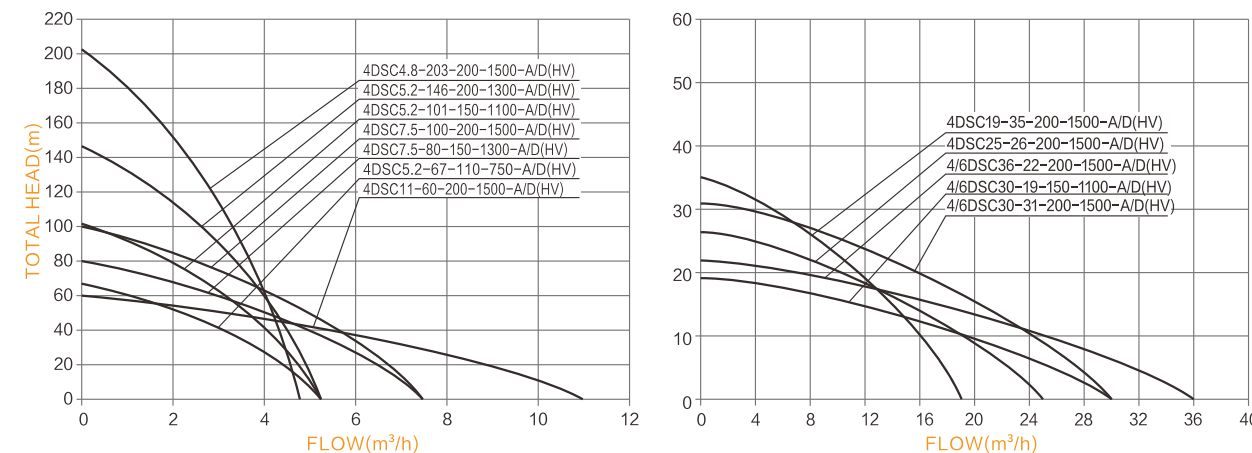

FREE SPARE PARTS



4DSC-A/D 4DSC-HV

4" AC/DC & WIDE VOLTAGE BRUSHLESS SOLAR PUMP WITH S/S IMPELLER

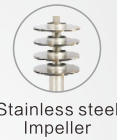

Stainless steel impeller



Stainless steel oil cylinder



NSK Bearing



AC/DC auto-switching controller (≤2.2KW)



Wide Voltage HV Controller

TECHNICAL DATA

ITEM	(AC) Voltage	(DC) Voltage	Power	Max. Flow	Max. Head	Outlet	Cable	Solar panel	
								Open circuit voltage (VOC)	Power
4DSC5.2-255-300-2200-A/D	85V-280V	80V-430V	2200W	5.2m³/h	255m	1.25"	2m	<430V	≥1.3*PUMP POWER
4DSC5.2-255-300-2200-HV	/								
4DSC7.5-150-300-2200-A/D	85V-280V	80V-430V	2200W	7.5m³/h	150m	1.25"	2m	<430V	≥1.3*PUMP POWER
4DSC7.5-150-300-2200-HV	/								
4DSC11-120-300-2200-A/D	85V-280V	80V-430V	2200W	11m³/h	120m	2"	2m	<430V	≥1.3*PUMP POWER
4DSC11-120-300-2200-HV	/								
4DSC19-60-300-2200-A/D	85V-280V	80V-430V	2200W	19m³/h	60m	2"	2m	<430V	≥1.3*PUMP POWER
4DSC19-60-300-2200-HV	/								
4DSC30-36-300-2200-A/D	85V-280V	80V-430V	2200W	30m³/h	36m	2"	2m	<430V	≥1.3*PUMP POWER
4DSC30-36-300-2200-HV	/								
4/6DSC36-38-300-2200-A/D	85V-280V	80V-430V	2200W	36m³/h	38m	3"	2m	<430V	≥1.3*PUMP POWER
4/6DSC36-38-300-2200-HV	/								

HYDRAULIC PERFORMANCE CURVES

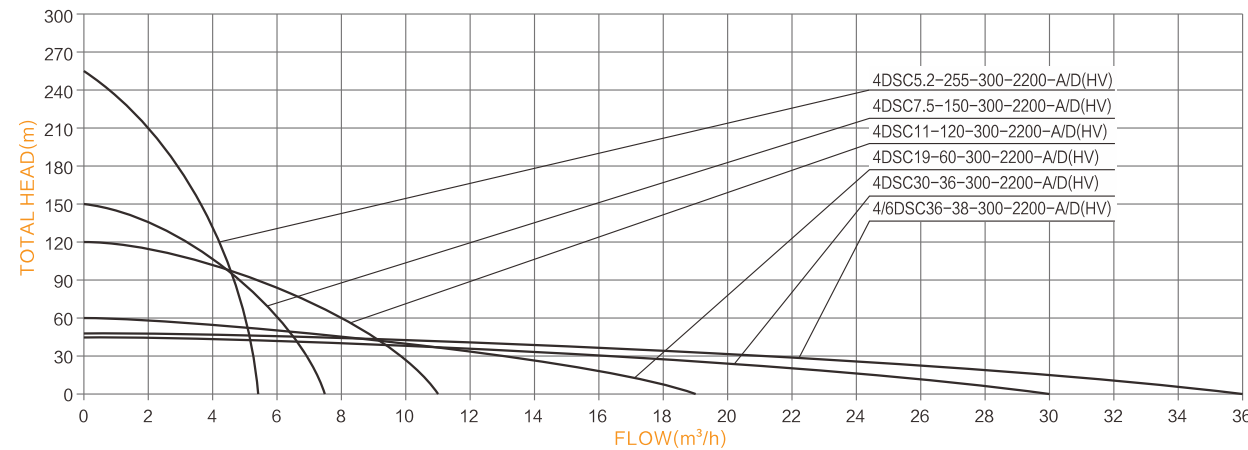

FREE SPARE PARTS



4DPC-A/D (3KW-7.5KW)

4" AC/DC BRUSHLESS SOLAR PUMP WITH PLASTIC IMPELLER

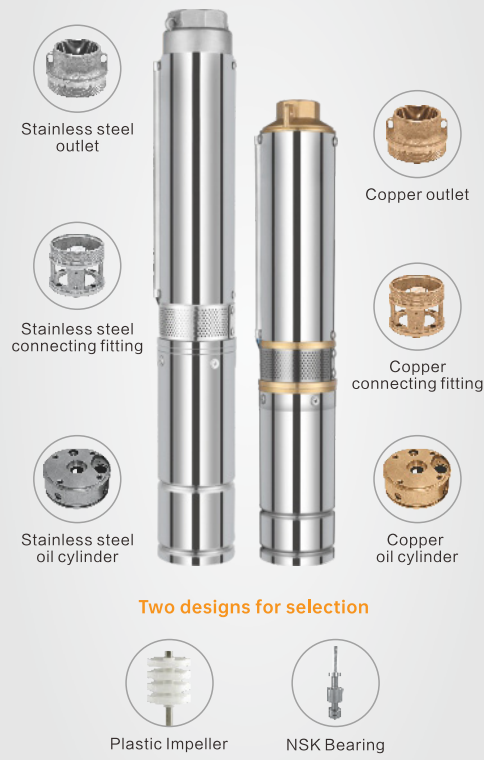

TECHNICAL DATA

ITEM	Voltage	Optimum input voltage (DC)	Power	Max. Flow	Max. Head	Outlet	Cable	Solar panel	
								Open circuit voltage (VOC)	Power
4DPC6-230-380/550-3000-A/D	AC380/DC550V	520V-650V	3000W	6m³/h	230m	1.25"	2m	<780V	≥1.3*PUMP POWER
4DPC6-300-380/550-4000-A/D	AC380/DC550V	520V-650V	4000W	6m³/h	300m	1.25"	2m	<780V	≥1.3*PUMP POWER
4DPC9.5-195-380/550-3000-A/D	AC380/DC550V	520V-650V	3000W	9.5m³/h	195m	2"	2m	<780V	≥1.3*PUMP POWER
4DPC9.5-250-380/550-4000-A/D	AC380/DC550V	520V-650V	4000W	9.5m³/h	250m	2"	2m	<780V	≥1.3*PUMP POWER
4DPC9.5-325-380/550-5500-A/D	AC380/DC550V	520V-650V	5500W	9.5m³/h	325m	2"	2m	<780V	≥1.3*PUMP POWER
4DPC13-150-380/550-3000-A/D	AC380/DC550V	520V-650V	3000W	13m³/h	150m	2"	2m	<780V	≥1.3*PUMP POWER
4DPC13-190-380/550-4000-A/D	AC380/DC550V	520V-650V	4000W	13m³/h	190m	2"	2m	<780V	≥1.3*PUMP POWER
4DPC13-240-380/550-5500-A/D	AC380/DC550V	520V-650V	5500W	13m³/h	240m	2"	2m	<780V	≥1.3*PUMP POWER
4DPC13-270-380/550-7500-A/D	AC380/DC550V	520V-650V	7500W	13m³/h	270m	2"	2m	<780V	≥1.3*PUMP POWER
4DPC17-110-380/550-3000-A/D	AC380/DC550V	520V-650V	3000W	17m³/h	110m	2"	2m	<780V	≥1.3*PUMP POWER
4DPC17-140-380/550-4000-A/D	AC380/DC550V	520V-650V	4000W	17m³/h	140m	2"	2m	<780V	≥1.3*PUMP POWER
4DPC17-175-380/550-5500-A/D	AC380/DC550V	520V-650V	5500W	17m³/h	175m	2"	2m	<780V	≥1.3*PUMP POWER
4DPC17-220-380/550-7500-A/D	AC380/DC550V	520V-650V	7500W	17m³/h	220m	2"	2m	<780V	≥1.3*PUMP POWER
4DPC22-98-380/550-4000-A/D	AC380/DC550V	520V-650V	4000W	22m³/h	98m	2"	2m	<780V	≥1.3*PUMP POWER
4DPC22-135-380/550-5500-A/D	AC380/DC550V	520V-650V	5500W	22m³/h	135m	2"	2m	<780V	≥1.3*PUMP POWER
4DPC22-170-380/550-7500-A/D	AC380/DC550V	520V-650V	7500W	22m³/h	170m	2"	2m	<780V	≥1.3*PUMP POWER

HYDRAULIC PERFORMANCE CURVES

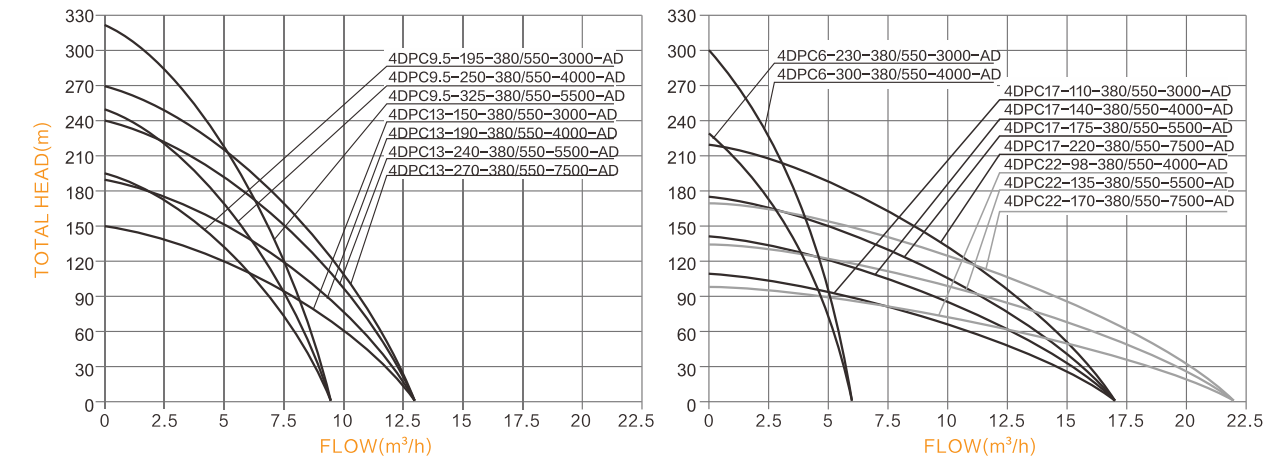

FREE SPARE PARTS



4DSC-A/D

4" AC/DC BRUSHLESS SOLAR PUMP WITH S/S IMPELLER



Stainless steel Impeller



Stainless steel oil cylinder



NSK Bearing



AC/DC auto-switching controller (5.5KW-22KW)



AC/DC auto-switching controller (3KW-4KW)

TECHNICAL DATA

ITEM	Voltage	Optimum input voltage (DC)	Power	Max. Flow	Max. Head	Outlet	Cable	Solar panel	
								Open circuit voltage(VOC)	Power
4DSC5.2-300-380/550-3000-A/D	AC380/DC550V	520V-650V	3000W	5.2m³/h	300m	1.25"	2m	<780V	≥1.3*PUMP POWER
4DSC7.5-210-380/550-3000-A/D	AC380/DC550V	520V-650V	3000W	7.5m³/h	210m	1.25"	2m	<780V	≥1.3*PUMP POWER
4DSC8-272-380/550-4000-A/D	AC380/DC550V	520V-650V	4000W	8m³/h	272m	1.25"	2m	<780V	≥1.3*PUMP POWER
4DSC11-157-380/550-3000-A/D	AC380/DC550V	520V-650V	3000W	11m³/h	157m	2"	2m	<780V	≥1.3*PUMP POWER
4DSC11-200-380/550-4000-A/D	AC380/DC550V	520V-650V	4000W	11m³/h	200m	2"	2m	<780V	≥1.3*PUMP POWER
4DSC19-98-380/550-3000-A/D	AC380/DC550V	520V-650V	3000W	19m³/h	98m	2"	2m	<780V	≥1.3*PUMP POWER
4DSC19-135-380/550-4000-A/D	AC380/DC550V	520V-650V	4000W	19m³/h	135m	2"	2m	<780V	≥1.3*PUMP POWER
4DSC19-170-380/550-5500-A/D	AC380/DC550V	520V-650V	5500W	19m³/h	170m	2"	2m	<780V	≥1.3*PUMP POWER
4DSC30-52-380/550-3000-A/D	AC380/DC550V	520V-650V	3000W	30m³/h	52m	2"	2m	<780V	≥1.3*PUMP POWER
4DSC30-74-380/550-4000-A/D	AC380/DC550V	520V-650V	4000W	30m³/h	74m	2"	2m	<780V	≥1.3*PUMP POWER
4DSC30-96-380/550-5500-A/D	AC380/DC550V	520V-650V	5500W	30m³/h	96m	2"	2m	<780V	≥1.3*PUMP POWER
4DSC30-155-380/550-7500-A/D	AC380/DC550V	520V-650V	7500W	30m³/h	155m	2"	2m	<780V	≥1.3*PUMP POWER

HYDRAULIC PERFORMANCE CURVES

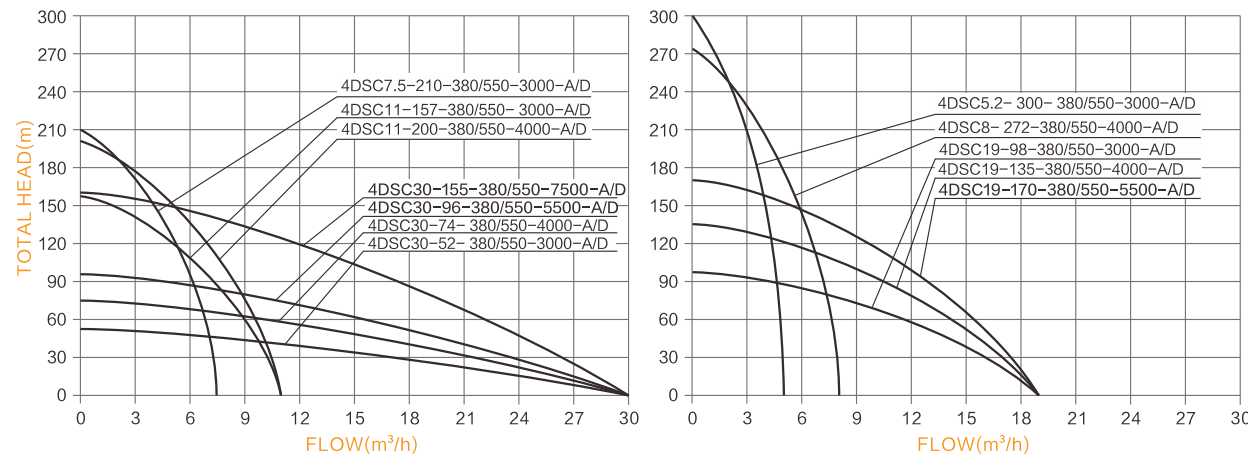

FREE SPARE PARTS



4/6DSC-A/D

6" AC/DC BRUSHLESS SOLAR PUMP WITH S/S IMPELLER



Stainless steel Impeller



Stainless steel oil cylinder



NSK Bearing



AC/DC auto-switching controller (5.5KW-22KW)



AC/DC auto-switching controller (3KW-4KW)

TECHNICAL DATA

ITEM	Voltage	Optimum input voltage (DC)	Power	Max. Flow	Max. Head	Outlet	Cable	Solar panel	
								Open circuit voltage(VOC)	Power
4/6DSC36-56-380/550-3000-A/D	AC380/DC550V	520V-650V	3000W	36m³/h	56m	3"	2m	<780V	≥1.3*PUMP POWER
4/6DSC36-75-380/550-4000-A/D	AC380/DC550V	520V-650V	4000W	36m³/h	75m	3"	2m	<780V	≥1.3*PUMP POWER
4/6DSC36-98-380/550-5500-A/D	AC380/DC550V	520V-650V	5500W	36m³/h	98m	3"	2m	<780V	≥1.3*PUMP POWER
4/6DSC36-135-380/550-7500-A/D	AC380/DC550V	520V-650V	7500W	36m³/h	135m	3"	2m	<780V	≥1.3*PUMP POWER

HYDRAULIC PERFORMANCE CURVES

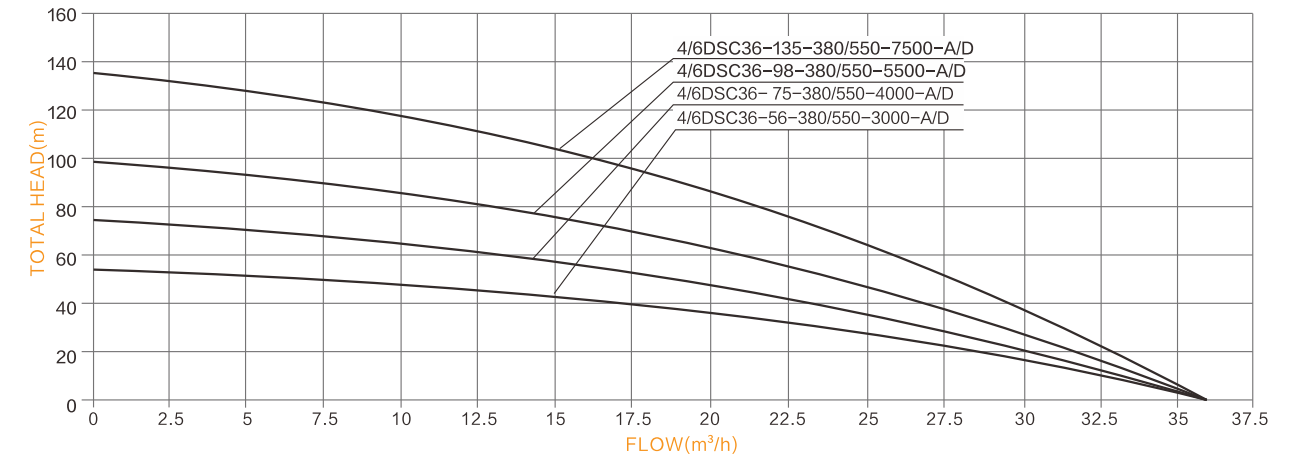

FREE SPARE PARTS

